

SCALE 0.375

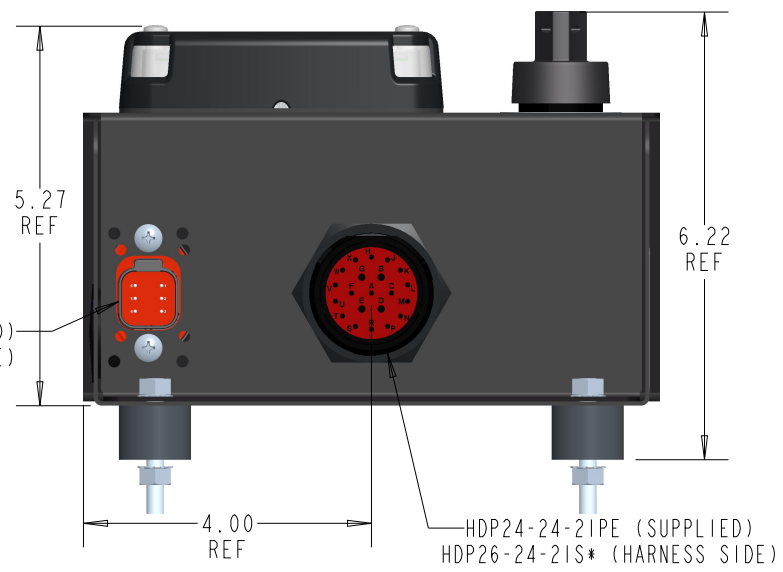

DT04-6P-CL09 (SUPPLIED)
DT06-6S* (HARNESS SIDE)

HDP24-24-21PE (SUPPLIED)
HDP26-24-21S* (HARNESS SIDE)

TOLERANCES ON DIMENSIONS UNLESS OTHERWISE SPECIFIED		 WWW.CONTROLSINC.COM 330-239-4345	
DECIMAL PLACE TOLERANCES	0.0 = ±0.060		
	0.00 = ±0.030	DESCRIPTION:	
0.000 = ±0.010	ANGLES: XX = ±0.5°	DRAWING UNITS UNLESS SPECIFIED: INCHES	
DRAWING UNITS UNLESS SPECIFIED: INCHES		MATERIAL: REFERENCE BILL OF MATERIAL	
DRAWN BY: KLD	DATE: 30-Nov-2022	STATUS: RELEASED	
LAST RELEASE: KLD	DATE: 29-Dec-2022	DRAWING NUMBER: RX-3100	
MODEL: RX	CONFIGURATION: 3100	SHEET: 1 OF 1	REV: -

REV:	DATE:	BY:	DESCRIPTION: