

ATMOSPHERIC VENT PATCH
VERTICAL INSTALLATION PREFERRED,
DO NOT BLOCK

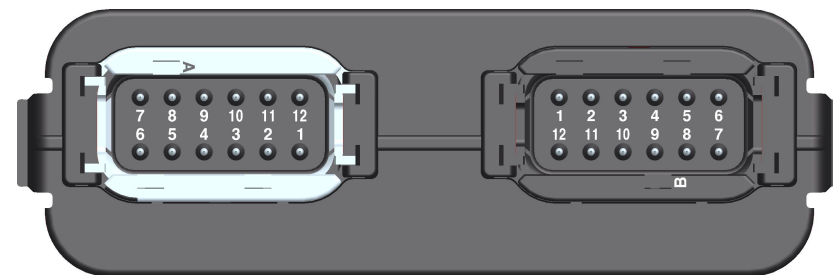

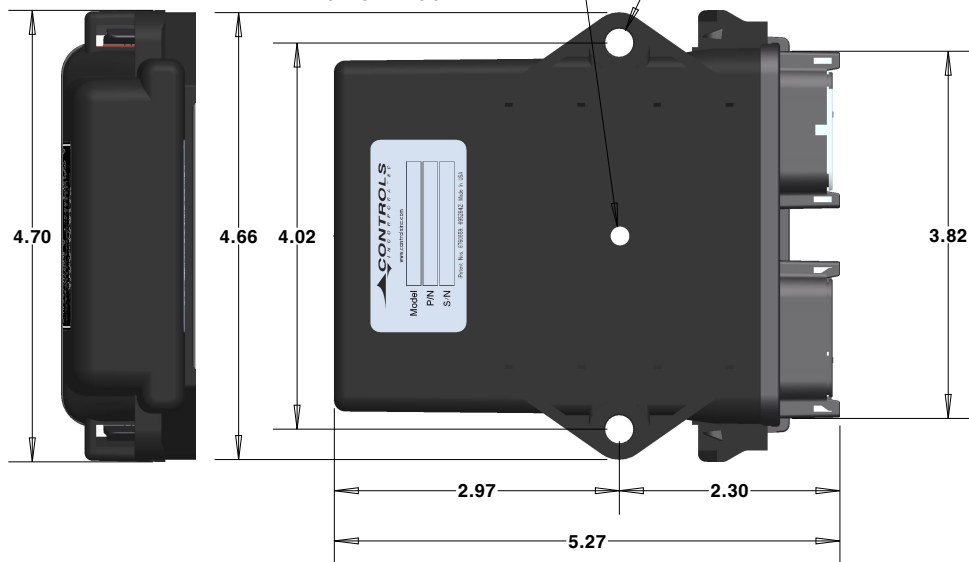

MATING CONNECTOR:
DTM06-12SA (GREY-A KEY)
0462-201-20141 SOCKET
0413-204-2005 SEAL

MATING CONNECTOR:
DTM06-12SB (BLACK-B KEY)
0462-201-20141 SOCKET
0413-204-2005 SEAL

DTM06-12SA (GREY-A KEY)	
1	FLEX ANALOG IN, 6
2	FLEX ANALOG IN, 5
3	FLEX ANALOG IN, 4
4	FLEX ANALOG IN, 3
5	FLEX ANALOG IN, 2
6	FLEX ANALOG IN, 1
7	V+ OUT 1
8	V+ OUT 2
9	V+ OUT 3
10	V+ OUT 4
11	V+ OUT 5
12	V+ OUT 6
*4-20mA DEFAULT INPUT CONFIGURATION	
0-5V INPUT AVAILABLE, FACTORY SETUP	

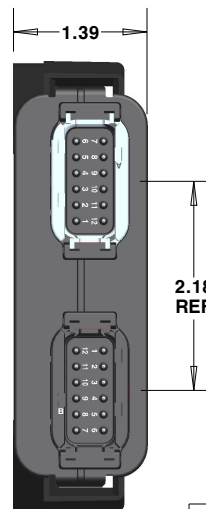
DTM06-12SB (BLACK-B KEY)	
1	V BATTERY +
2	V+ OUT 7
3	V+ OUT 8
4	V+ OUT 9
5	V+ OUT 10
6	CAN LOW
7	CAN HIGH
8	FLEX ANALOG IN, 10
9	FLEX ANALOG IN, 9
10	FLEX ANALOG IN, 8
11	FLEX ANALOG IN, 7
12	GROUND
*4-20mA DEFAULT INPUT CONFIGURATION	
0-5V INPUT AVAILABLE, FACTORY SETUP	



TOLERANCES ON DIMENSIONS UNLESS OTHERWISE SPECIFIED		 WWW.CONTROLSINC.COM 330-239-4345	
DECIMAL PLACE TOLERANCES	0.0 = ±0.060	NEXT ASS'Y:	10 ANALOG EXPANSION MODULE FACTORY CONFIGURABLE 4-20mA OR 0-5V
	0.00 = ±0.030	DESCRIPTION:	
	0.000 = ±0.010	MATERIAL: REFERENCE BILL OF MATERIAL	
ANGLES:	XX = ±0.5°	STATUS: RELEASED	
DRAWING UNITS UNLESS SPECIFIED: INCHES		DRAWING NUMBER:	REV:
DRAWN BY: KLD	DATE: 14-Sep1-2022	SHEET: 1 OF 1 XCAN-A10	
RELEASED:	DATE:		
MODEL: XCAN			
CONFIGURATION: A10			