

**MATING CONNECTOR:**  
DTM06-12SA (GREY-A KEY)  
0462-201-20141 SOCKET  
0413-204-2005 SEAL

**MATING CONNECTOR:**  
DTM06-12SB (BLACK-B KEY)  
0462-201-20141 SOCKET  
0413-204-2005 SEAL

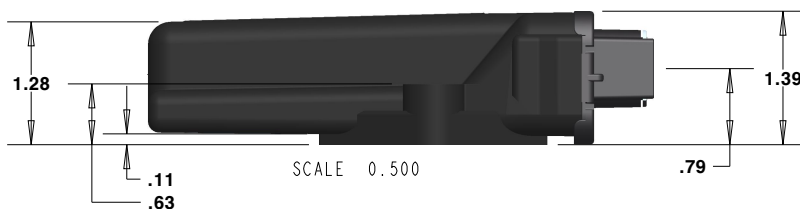

PINS	12PA FUNCTIONS
1	CT PHASE A RETURN
2	CT PHASE B RETURN
3	CT PHASE C RETURN
4	GENERATOR NEUTRAL
5	NOT USED
6	NOT USED
7	GENERATOR PHASE B
8	GENERATOR PHASE C
9	GENERATOR PHASE A
10	CT PHASE C
11	CT PHASE B
12	CT PHASE A

PINS	12PB FUNCTIONS
1	V BATTERY +
2	NOT USED
3	NOT USED
4	NOT USED
5	CAN LOW
6	GROUND (V-)
7	GROUND (V-)
8	CAN HIGH
9	NOT USED
10	NOT USED
11	NOT USED
12	V BATTERY +

ATMOSPHERIC VENT PATCH  
VERTICAL INSTALLATION PREFERRED,  
DO NOT BLOCK

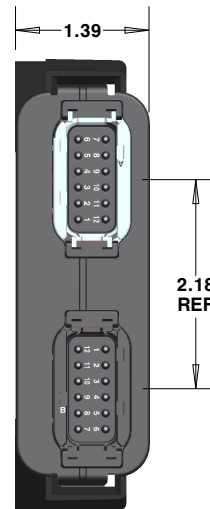
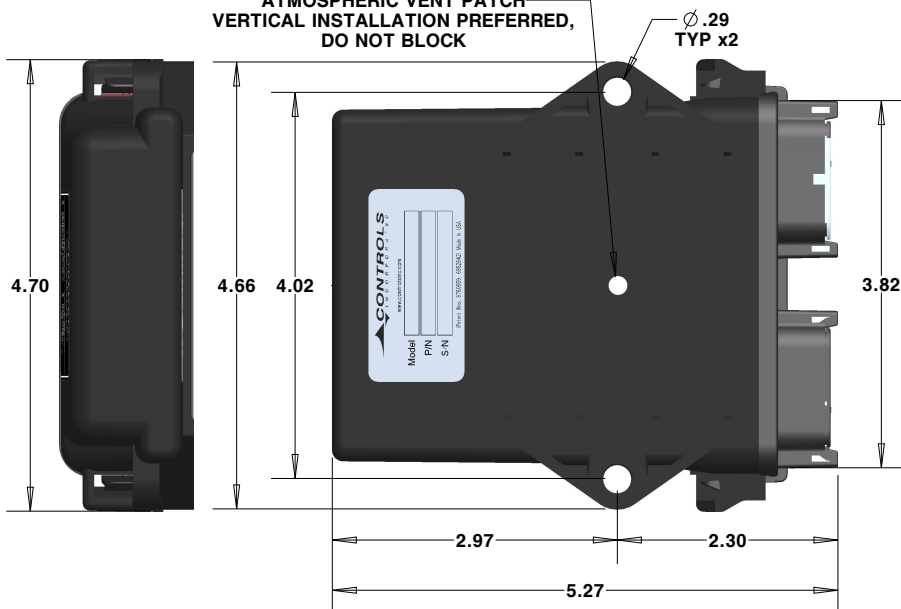

TOLERANCES ON DIMENSIONS UNLESS OTHERWISE SPECIFIED		 WWW.CONTROLSINC.COM 330-239-4345	
DECIMAL PLACE TOLERANCES	0.0 = ±0.060 0.00 = ±0.030 0.000 = ±0.010		
ANGLES:	XX = ±0.5°	DESCRIPTION:	
DRAWING UNITS UNLESS SPECIFIED: INCHES		MATERIAL:	REFERENCE BILL OF MATERIAL
DRAWN BY: KLD	DATE: 01-June-21	STATUS:	RELEASED
CHECKED BY:	DATE:	DRAWING NUMBER:	XCAN-AC
MODEL: XCAN-AC		REV:	A
CONFIGURATION:		SHEET: 1 OF 1	